

## PRODUCT SPECIFICATION

MODEL NO	HD027VCR
INPUT	12VDC
DESCRIPTION	SECTOR DIPOLE ANTENNA MICROWAVE SENSOR
CERTIFICATE	CE RED

## SECTOR DIPOLE ANTENNA MICROWAVE SENSOR

WRITTEN BY	夏勇
CHECKED BY (R&D)	
CONFIRMED BY (SALES)	同蒙
DATE	2022.09.24

## Features & Benefits

### HD027VCR

- Special Sector Dipole Antenna Design.
- Compact & Integrated Size Design.
- Max. Installation Height as 6M.
- AC 220-240V ON/OFF Version available, Model HD019S/HD019SR

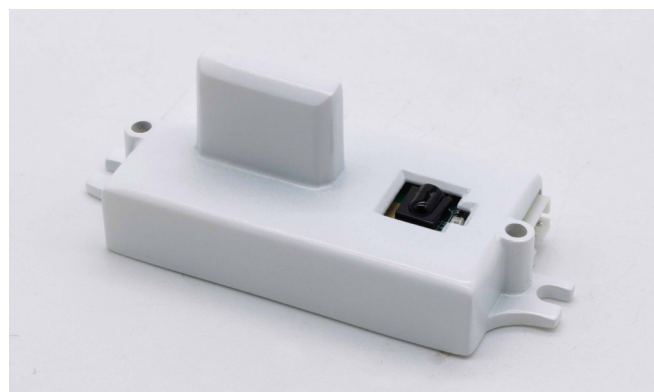

## Dimensions

Unit:mm

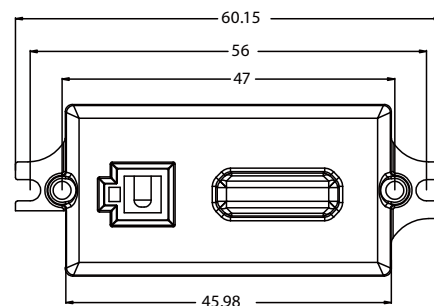
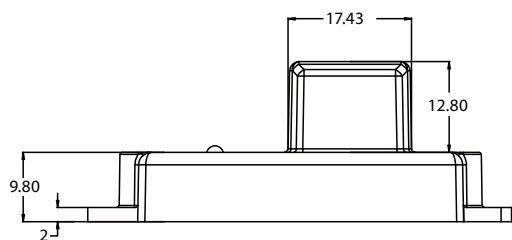
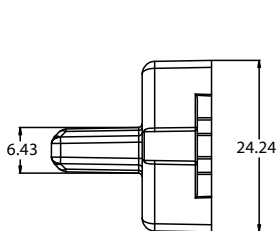

## Detection Coverage

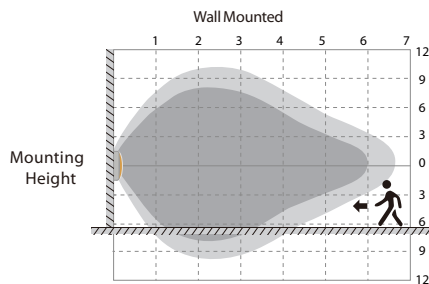
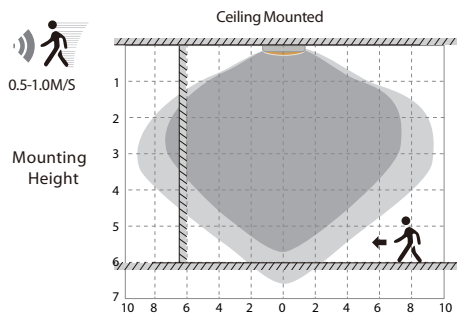

Highest mounting height is 6m

This figure indicates the maximum distance at the highest mounting height with 100% sensitivity.

Well Detected Area      Possibly Detected Area

# Parameters

Model NO.		HD027VCR
MICROWAVE INFORMATION	Frequency	5.8GHz±75MHz
	Microwave Power	<0.3mW
	Installation Height	2.5-6m/8.2-19.68ft Ceiling Mounted
	Detection Distance	Radius ≤3m/9.84ft Ceiling Mounted
	Detection Angle	Side Wall<150° Ceiling Mounted 360°
	Motion Detection	0.5~1.5m/s
	Warranty	5 years
SENSOR PARAMETER	Detection Area	25%/50%/75%/100%
	Holdtime	5s/30s/1min/3min/5min/10min/20min/30min
	Daylight Threshold	2Lux/10Lux/30Lux/50Lux/80Lux/120Lux/200Lux/250Lux/ 300Lux/350Lux/400Lux/Disable
	Standby Dimming Level	10%/20%/30%/50%
	Standby Period	0s/10s/30s/1min/5min/10min/30min/60min/+ ∞
	Remote Model	Standard Partner HD05R, the LCD screen display remote (purchase seperately)
INPUT	Input Voltage	10-15V
	Operating Current	<30mA
OUTPUT	Control Method	0-10V
	Quick Connector	3-pin Connection
ENVIRONMENT	Working Temp	-35°C~+60°C
CERTIFICATE & STANDARDS	Environmental Requirements	In accordance with CE RED
	IP Rating	IP20

# Wiring Diagram

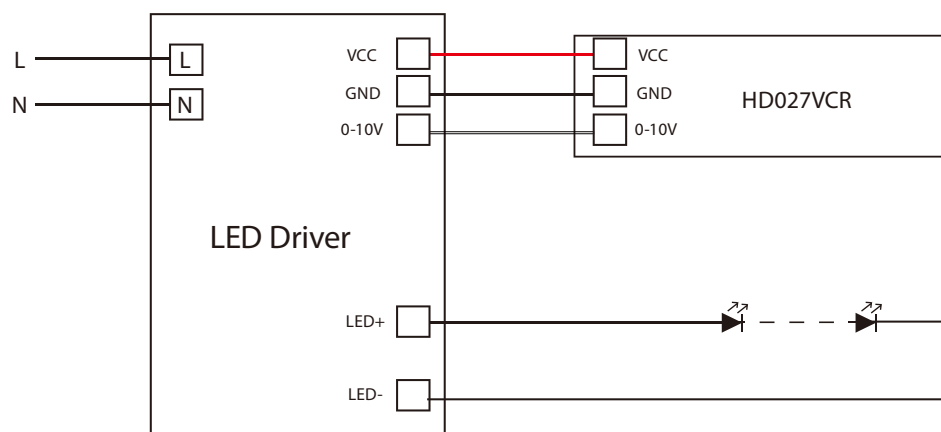

# Performance

## 1. Automatically ON/OFF function

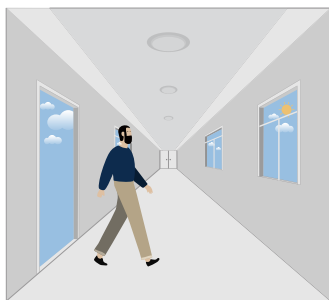

With sufficient daylight, even when motion detected, light remains OFF.

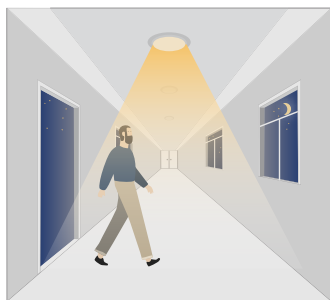

With insufficient daylight, the sensor turns light ON when motion gets detected.

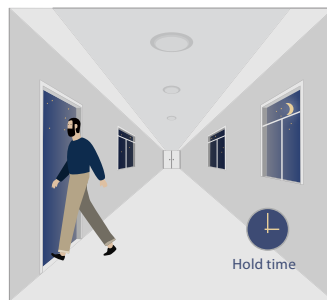

The sensor turns OFF light automatically after the holdtime when there's no motion detected.

## 2. Daylight Disable

When daylight threshold is preset as "disable", the sensor turns light ON when motion gets detected, and OFF after hold time.

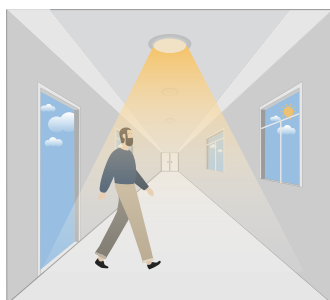

The sensor turns light ON when motion gets detected.

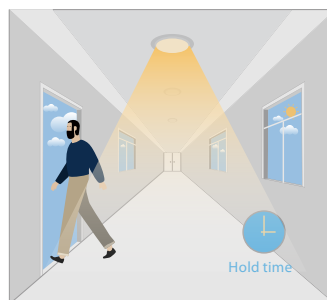

The sensor keeps light ON for holdtime period after motion leaves.

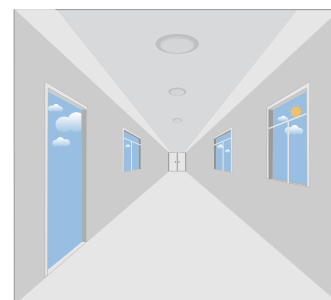

The sensor turns OFF light automatically after the holdtime.

## 3. Corridor Function, Bi-level Dimmable

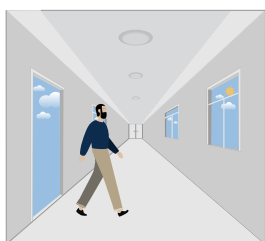

With sufficient daylight, the sensor keeps light OFF even motion gets detected.

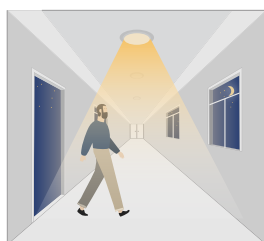

With insufficient daylight, the sensor turns light ON when motion gets detected.

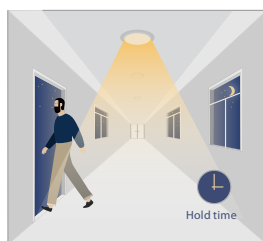

After there's no motion detected, the sensor keeps light ON 100% for holdtime.

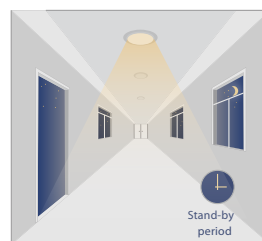

After holdtime, sensor dims light to standby dimming level for standby period.

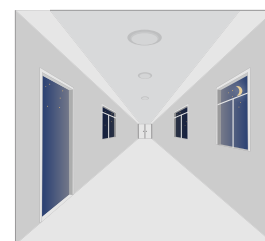

The sensor turns OFF light automatically after the standby period when there's no motion detected.



## Attention

1. The sensor should be installed by qualified electrician and ensure power is OFF before installation.
2. Please read the instruction carefully before using the product and keep it well for other users to read any time.
3. We reserve the right to modify any incorrect text, image and technical parameters.
4. Any unauthorized modification is forbidden. Otherwise all guarantees will be immediately invalid.
5. Product could be optimized without prior notice.

## APPLICATION NOTES

1. Suitable for indoor application, half/completely outdoor environment conditions might be captured as moving signals to trigger the sensor.
2. Suitable for ceiling mount installation, adjust sensitivity properly if it's installed on side-wall because it gets more sensitive.
3. Adjust sensitivity properly when the sensor is applied in small/narrow/metal-built/with metal spaces.
4. Microwave sensor can't be placed under/inside metal shell; Microwave module must directly face the detection area with edge lower than light fixture.
5. Keep the sensor away from vibration equipments, air-conditioning outlets, smoke extractors alike conditions to avoid unwanted trigger.
6. Keep the sensor module away from AC input and DC output to avoid high/low frequency signal interference.
7. At least 2m/6.5ft distance between microwave sensors; 1.5m/4.9ft between the sensor and other wireless devices such as routers to avoid possible radio interference.
8. Daylight testing delivered in bright day without shadow or specially designed lampshade or lens.
9. Dimming performance differs when connected to different drivers; If the driver can't completely turn OFF, sensor can't either.
10. Input power voltage must be stable with float less than 10%.
11. The first time powered ON sensor, light will be ON 100% for about 10S then dims to standby level or OFF.
12. Distance detection is delivered by testing person about 165cm in open area as reference, the result differs by size and speed of moving objects, mounting height and real-life situation.