

Installation Guide for Led Tube Type A+B

1.Replacement for magnetic ballast & electronic ballast fluorescent lamps(TypeA)

Installation steps

Magnetic ballast

professional installation is required

- 1:Turn off power before installation
- 2:Remove the traditional starter
- 3:Replace traditional fluorescent tube with LED tube
- 4:Switch on electricity and check for lamp starting

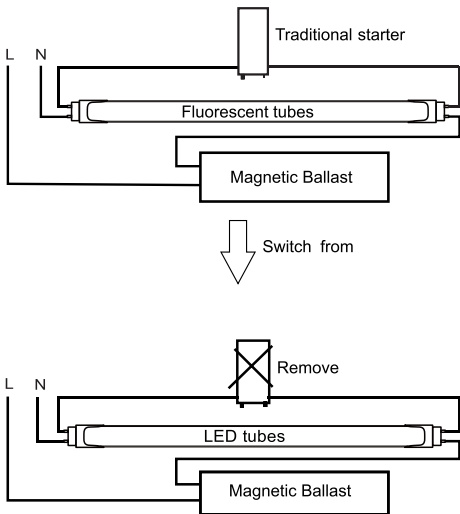

Electronic ballast

professional installation is required

- 1:Turn off power before installation
- 2:Replace traditional fluorescent tube with LED tube
- 3:Switch on electricity and check for lamp starting

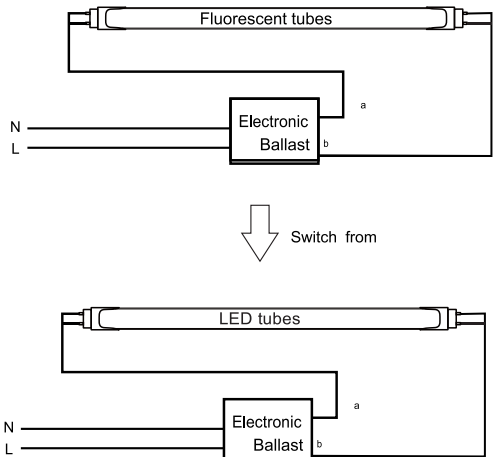

2.Replacement for bypass ballast fluorescent lamps(TypeB)

Installation Steps

- 1 : Turn off power before installation
- 2 : Cut the wire and bypass ballast
- 3 : Hookup line wires to Tombstone wires as a direct power
- 4 : Stick the warning label
- 5 : Switch on electricity and check for lamp starting

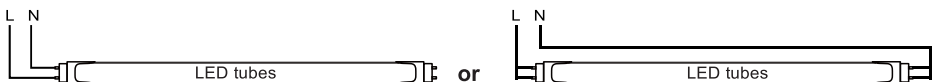

Warning: All fixture have to change with new tombstone when apply for plug and play tube.

WARNINGS

USE ONLY FIXED FIXTURES WITH MINIMUM LAMP COMPARTMENT DIMENSIONS:

450mm x 280mm x 80mm for 1.5ft tubes; 600mm x 280mm x 80mm for 3ft tubes ;

1200mm x 280mm x 80mm for 4ft tubes; 1500mm x 280mm x 80mm for 5ft tubes ;

1800mm x 280mm x 80mm for 6ft tubes; 2100mm x 280mm x 80mm for 7ft tubes;

2400mm x 280mm x 80mm for 8-foot tubes; 3000mm x 280mm x 80mm for 10-foot tubes.

WARNING - RISK OF FIRE OR ELECTRIC SHOCK. INSTALLATION OF THIS RETROFIT KIT REQUIRES A PERSON FAMILIAR WITH THE CONSTRUCTION AND OPERATION OF THE LUMINAIRE'S ELECTRICAL SYSTEM AND THE ASSOCIATED RISKS. ANYONE WHO IS NOT QUALIFIED SHOULD NOT ATTEMPT INSTALLATION AND SHOULD CONTACT A QUALIFIED ELECTRICIAN.

WARNING - RISK OF FIRE OR ELECTRIC SHOCK. INSTALL THIS KIT ONLY IN LUMINAIRES WHOSE CONSTRUCTION AND DIMENSIONS CONFORM TO THOSE SHOWN IN THE PHOTOS AND / OR DRAWINGS, AND WHOSE RETROFIT KIT INPUT RATING DOES NOT EXCEED THAT OF THE LUMINAIRE.

DO NOT MAKE OR MODIFY ANY OPENING IN A WIRING OR ELECTRICAL COMPONENTS DURING INSTALLATION.

WARNING - TO PREVENT DAMAGE OR ABRASION TO THE CABLES, AVOID CONTACT BETWEEN THEM AND THE EDGE OF A SHARP OBJECT SUCH AS SHEET METAL. THE RETROFIT KIT IS ACCEPTED AS A COMPONENT OF A LUMINAIRE WHEN THE SUITABILITY OF THE COMBINATION IS TO BE DETERMINED BY THE RELEVANT AUTHORITIES. THIS PRODUCT MUST BE INSTALLED BY A QUALIFIED ELECTRICIAN IN ACCORDANCE WITH THE APPROPRIATE APPLICABLE ELECTRICAL CODES. THE INSTALLATION GUIDE DOES NOT REPLACE LOCAL OR NATIONAL ELECTRICAL INSTALLATION REGULATIONS.

WARNING - TO AVOID RISK OF FIRE OR ELECTRIC SHOCK, DO NOT USE THIS RETROFIT KIT IN A FIXTURE THAT USES A SHUNTED TWO-PIN LAMP SOCKET. **NOTE:** SHUNTED LAMP HOLDERS ARE ONLY FOUND IN FLUORESCENT FIXTURES EQUIPPED WITH INSTANT-ON BALLASTS. INSTANT START BALLASTS CAN BE IDENTIFIED BY THE WORDS "INSTANT START" OR "I.S." ON THE BALLAST. THIS DESIGNATION MAY BE IN THE FORM OF A STATEMENT ABOUT THE BALLAST ITSELF, OR MAY BE COMBINED WITH THE MARKING OF THE LAMPS WITH WHICH THE BALLAST IS INTENDED TO BE USED (EXAMPLE: "F40T12 / IS"). FOR FURTHER INFORMATION, PLEASE CONTACT THE MANUFACTURER OF THE LED RETROFIT KIT.

INSTALLERS **SHOULD NOT** DISCONNECT EXISTING WIRING FROM TUBE SOCKET TERMINALS IN ORDER TO MAKE FURTHER CONNECTIONS TO THESE TERMINALS. INSTEAD, INSTALLERS SHOULD CUT THE EXISTING TUBE SOCKET WIRES AWAY FROM THE SOCKET AND MAKE NEW ELECTRICAL CONNECTIONS TO THE SOCKET WIRES USING FITTINGS SUITABLE FOR THIS PURPOSE.

THIS DEVICE **IS NOT SUITABLE** FOR EMERGENCY EXITS.