

INSTALLATION INSTRUCTIONS



LED LIGHT PANEL

PLEASE read these instructions carefully before installation and keep for reference.

CAUTION:

- THIS PRODUCT MUST BE INSTALLED IN ACCORDANCE WITH THE APPLICABLE INSTALLATION CODE BY A PERSON FAMILIAR WITH THE CONSTRUCTION AND OPERATION OF THE PRODUCT AND THE HAZARDS INVOLVED
- SUITABLE FOR OPERATION IN AMBIENT NOT EXCEEDING 40°C
- SUITABLE FOR DAMP LOCATIONS
- MIN 90°C SUPPLY CONDUCTORS
- CLASS 1 WIRING
- TYPE IC
- INHERENTLY PROTECTED
- ACCESS ABOVE CEILING REQUIRED
- VAPOR BARRIER MUST BE SUITABLE FOR 90°C

NOTE: Please comply with all warnings to ensure validity of warranty and personal safety.



Step 1. Replace existing lighting fixture from ceiling with LED Light Panel.

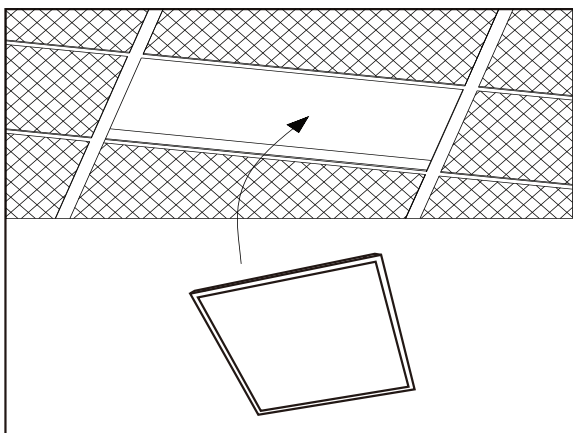

Step 2. Use the protective brackets for the sake of safety.

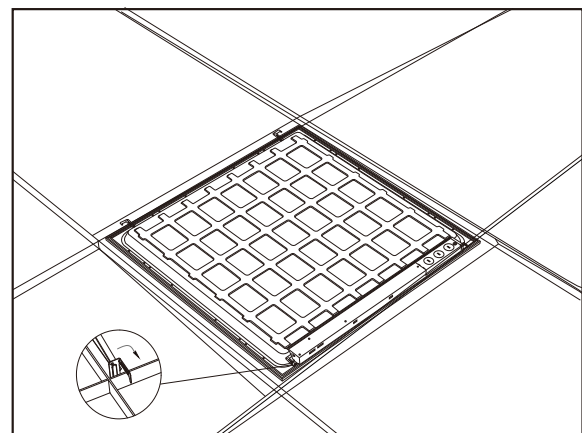

Step 3. Unscrew the driver cover.

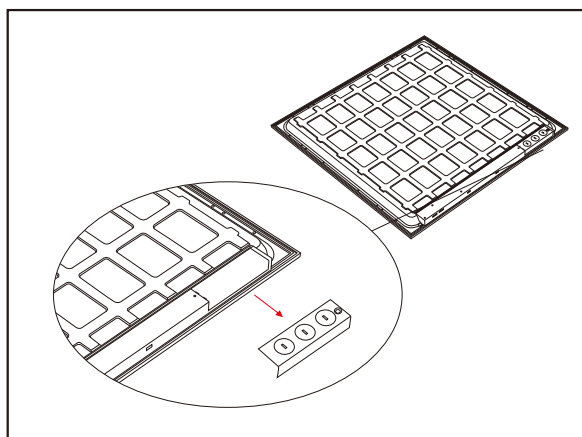

Step 4. Connect other wires separately.

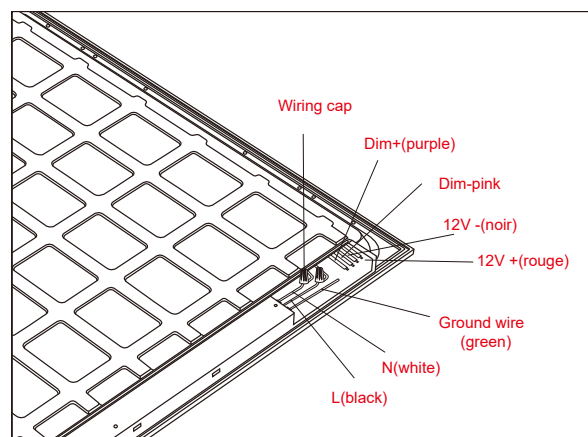

Step 5. Cover the power supply cover and lock the screws

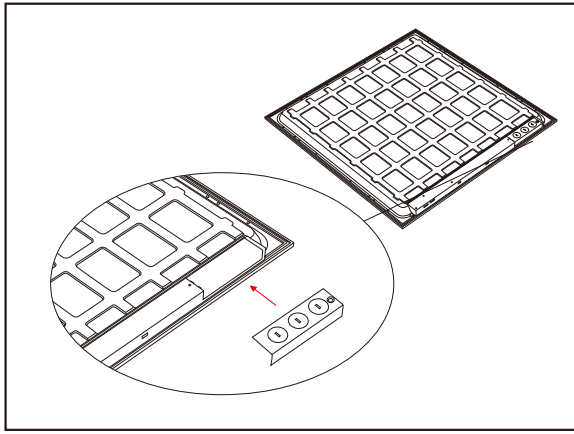

Step 6. Put the power cord into the driver box.

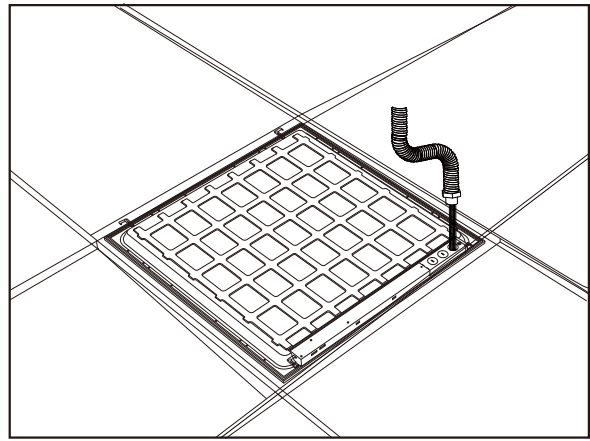

Step 7. Tighten the power cord and the installation is complete.

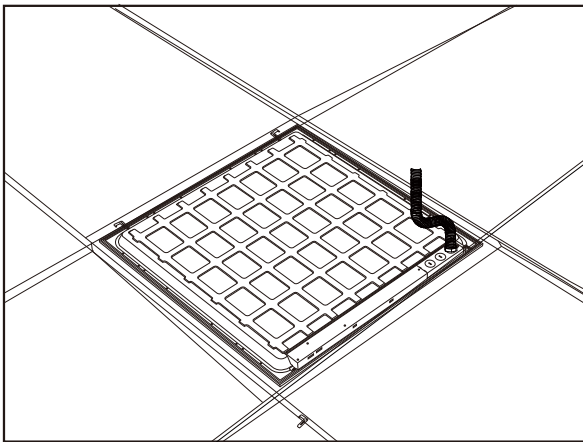

5 Wattages selectable, 5 CCT selectable

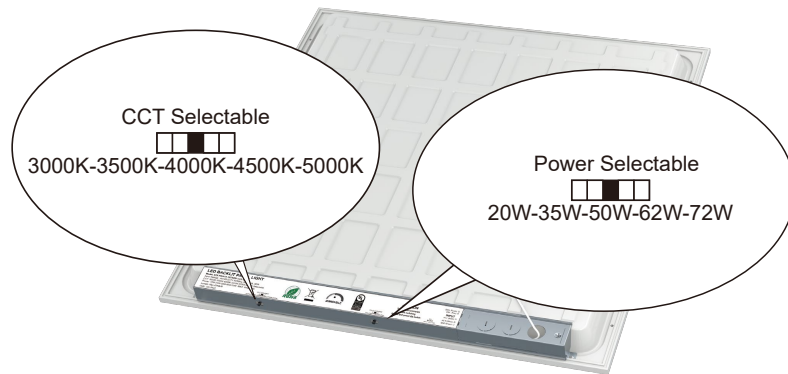

WIRING DIAGRAM:

