

1. DESCRIPTION:

This emergency light is constructed with steel housing and lightweight thermal plastic head in matching color. It is presented a simple and modern design with high efficiency LED remote heads. Universal mounting pattern and keyhole slots are stamped on the back and conduit knockouts on the sides of each unit.

2. CIRCUITS:

Electrical parameters
Working voltage: AC120V; AV347V 50Hz/60Hz
Input Wattage: 18W-21W
Output Wattage: 2*5W(lamp head) ;Max:265W 2*2W(lamp head) ;Max:271W
Color temperature: 6500K-7500K; Ultra bright LED
Recharge time: 45 Hours
Emergency duration: \geq 30 minutes (275W)
Lead-Acid Battery 12V/12Ah*2pcs

3. PRODUCT SIZE:

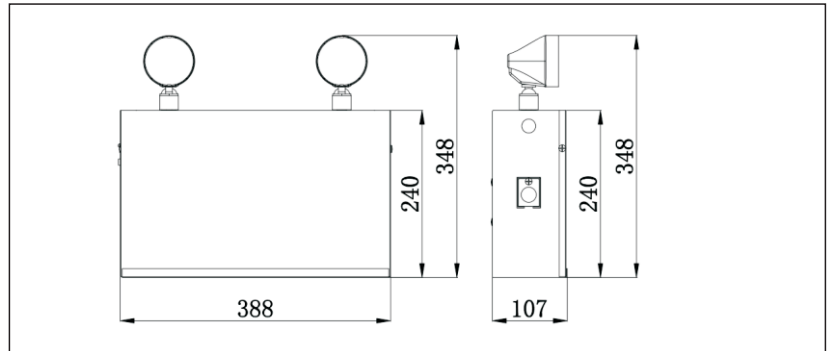

4. ATTENTION:

- 4.1. READ AND FOLLOW ALL SAFETY INSTRUCTIONS.
- 4.2. For Indoor use ONLY.
- 4.3. Do not let power cords touch hot surfaces.
- 4.4. Do not install near gas or electric heaters.
- 4.5. Use caution when servicing batteries. Battery acid can cause burns to skin and eyes. If acid is spilled on skin or eyes, flush acid with fresh water and contact a physician immediately.
- 4.6. Equipment should be mounted in locations and at heights where unauthorized personnel will not readily subject it to tampering.
- 4.7. The use of accessory equipment not recommended by manufacturer, may cause an unsafe condition, and will void the unit's warranty.
- 4.8. Do not use this equipment for other than its intended purpose.
- 4.9. Servicing of this equipment should be performed by qualified service personnel.
- 4.10. SAVE THESE INSTRUCTIONS FOR FUTURE REFERENCE.

5. INSTALLATION INSTRUCTIONS:

5.1. Hardwired Installation:

- 5.1.1. Extend un-switched 35 hour AC supply of rated voltage to a junction box (supplied by others) installed in accordance with all applicable codes and standards. Leave a minimum of 8 inches of slack on the wire. This circuit should NOT be energized/live at this time.
- 5.1.2. Open the unit by unscrewing the cover screws on the sides of the unit. The front cover can then be removed.
- 5.1.3. Unit is supplied with universal spider knockouts and keyhole slots stamped into the back of the cabinet. Knock out the appropriate hole(s) and bring wires through the hole(s) into the cabinet.
- 5.1.4. Mount the unit securely into place. Do not rely on the electrical box as the only support for the unit. See 5.1.2 Line Cord Installation shown above for further details.
- 5.1.5. Make proper wiring connections between the AC supply and the unit's transformer: Red-Line: AC 347V、 Black -Line AC120 Volts; White-Line: Neutral ;Green - Line Earth; (Fig.3).
Insulate unused wire! Connect ground to supplied green ground wire in accordance with local codes. Reassemble all wire connections and connectors.

CAUTION! – Failure to insulate unused wire may result in a shock hazard or unsafe condition as well as well as equipment failure.

- 5.1.6. Batteries on larger units may be shipped separately to avoid damage in shipping. Install batteries into the cabinet and complete the appropriate battery connections (Fig.2)
- 5.1.7. Batteries already installed in the cabinet must be connected to the circuit board (Fig. 2, 3).
- 5.1.8. Secure all internal wires.
- 5.1.9. Replace cover and secure cover screws.
- 5.1.10. Turn on AC line voltage supply.
- 5.1.11. If the unit is supplied with a line cord, connect the line cord plug into the appropriate receptacle previously installed.
- 5.1.12. If unit is complete with lamp heads, position the lamp heads to provide best lighting distribution by loosening head set screws to adjust angle and swivel. Manually rotate or turn head(s) to the desired

position, then tighten set screws to lock position.

5.4. OPERATION

- 5.4.1. To Test, depress the TEST Switch. Charge indicator will go out and the DC lamps will come on.
- 5.4.2. Release the TEST Switch. DC lamps will be extinguished, and the charge indicator will come on.
- 5.4.3. A bright charge LED indicator light indicates a high charge rate. After the battery has reached full charge, the indicator light will go out. Under normal operation the high charge indicator will turn on and off intermittently while the unit is in standby mode (regular AC is present) since the charge rate will vary in order to maintain an optimal battery performance.

5.5. MAINTENANCE

- 5.5.1. Code requires that the equipment be tested every 30 days for 30 seconds, and that written records be maintained for all test results and repairs. Further, the equipment is to be tested once a year for the required duration as per Code. The battery is to be replaced or the equipment repaired whenever the equipment fails to operate as intended during the duration test. The manufacturer strongly recommends compliance with all Code requirements.

- 5.5.2. Clean lenses on a regular basis to provide maximum light distribution in case of an emergency.

NOTE: The servicing of any parts should be performed by qualified service personnel only. The use of replacement parts not furnished by the manufacturer, may cause equipment failure and will void the warranty.

6. TROUBLESHOOTING HINTS:

EMERGENCY LAMPS DO NOT COME ON AT ALL

Pilot Light is out before test...

- 6.1.1. Check AC supply - be sure unit has 35 hour AC supply (un-switched).
- 6.1.2. AC supply is OK, and indicator light is out, replace PC Board Assembly. Pilot Light is on before test.
- 6.1.3. Either the output is shorted or overloaded, or the battery is not connected.
- 6.1.4. Battery is severely discharged. Allow 35 hours for recharge and then retest. NOTE: This could be the result of a switched AC supply to the unit (which has been turned off at some point), a battery with a shorted cell, an old battery or a battery which has been discharged due to a long power outage and is not yet fully recharged.

EMERGENCY LAMPS COME ON DIM WHEN TEST BUTTON IS PRESSED

Battery discharged - permit unit to charge for 35 hours and then retest. If lamps are still dim, check charger for proper function. If charger functions correctly, replace battery.

EMERGENCY LAMPS COME ON WHEN BATTERY IS FIRST CONNECTED

Battery may be connected in reverse polarity. Check connections. Connect Positive lead to Positive battery terminal and Negative lead to Negative battery terminal. The lamps should then turn off and the charge indicator should light when AC power is applied. (Fig.3)

EMERGENCY LAMPS COME ON DIM WHEN AC POWER IS ON

Check supply voltage and AC connections. This emergency light is provided with brownout protection.

The AC supply must be at least 80% of nominal (120V on a 347V line) for equipment to function normally. At lower voltages the emergency lamps will begin to glow dimly until the source voltage drops below the full turn-on point. NOTE: This condition may also be caused by incorrectly connecting a 120 Volt supply line to the 347-Volt transformer lead.

NOTHING HAPPENS WHEN THE UNIT IS ENERGIZED

Some models have a standard time delay built into the design of the charger board. Please allow 15 minutes with AC current connected. At this point the LED AC-ON and CHARGE lights should illuminate.

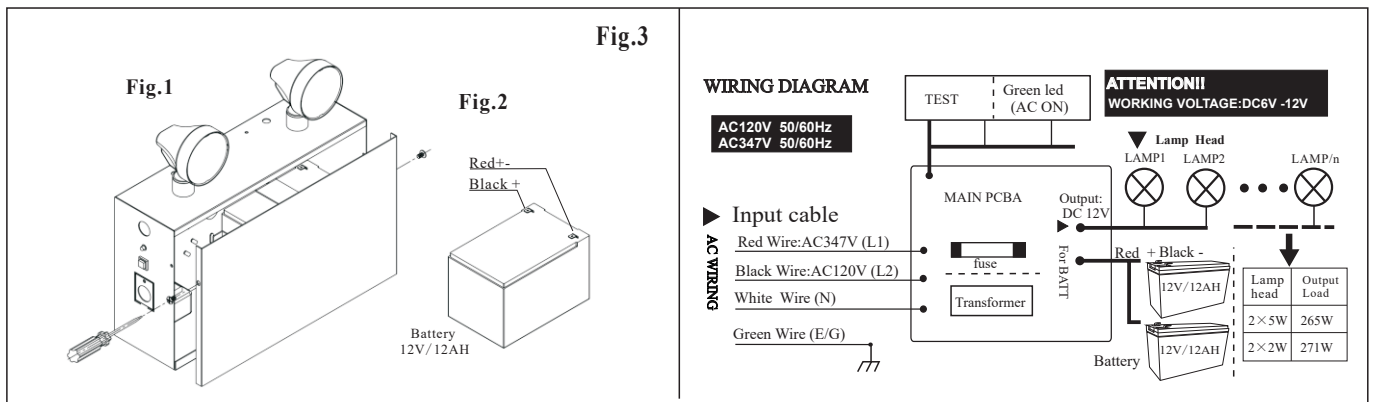

Fig.4.1

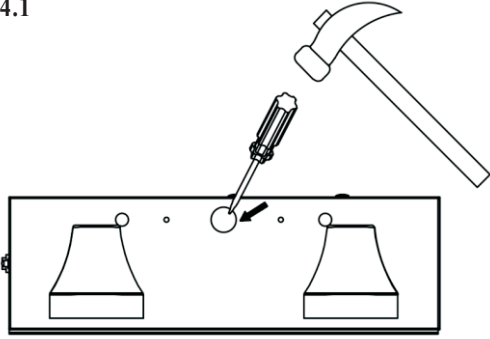

Fig.4.2

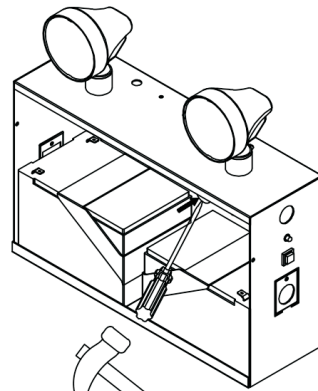
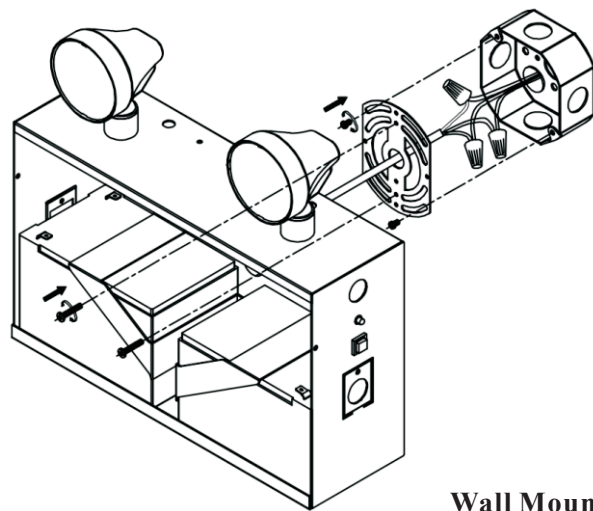

Fig.4.3



Wall Mount

Fig.6

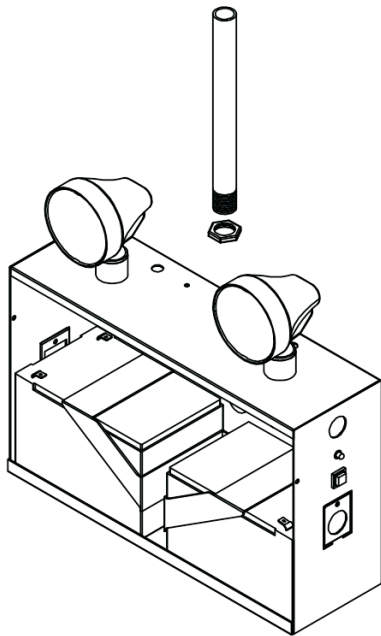

Fig.5

