

WARNING
ELECTRICAL SHOCK HAZARD
AVERTISSEMENT
RISQUE D ELECTROCUTION

READ AND UNDERSTAND THESE INSTRUCTIONS BEFORE
INSTALLING LUMINAIRE
LISEZ CETTE NOTICE ET ASSUREZ-VOUS DE LA
COMPRENDRE AVANT DE MONTER LE LUMINAIRE

Model list:

Model No.	TLESMU01
Rated voltage	AC120/347V~, 60Hz, 50mA
Operating mode	Maintained
Input Power	4W
Emergency Power	1.8W
Charge Time	24 hrs
Emergency Duration	90 mins
Battery	Ni-Cd 3,6V 600mAh
Battery life	up to 4 years
Power factor	>0.5
Operating Temp Range	0-40 °C
IP degree	IP20
Dimensions	312×195×56mm
Warranty	2 years

Installation instruction diagram

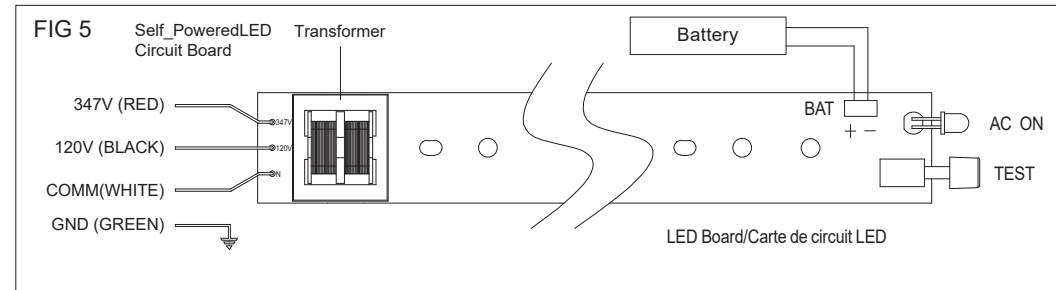
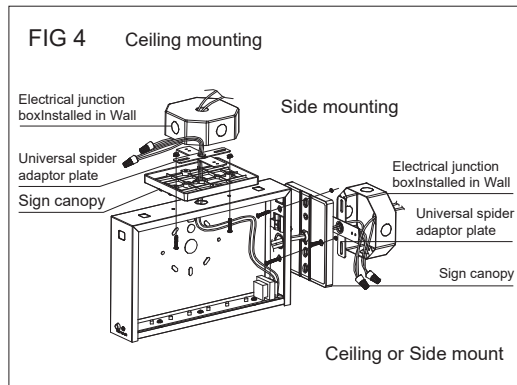
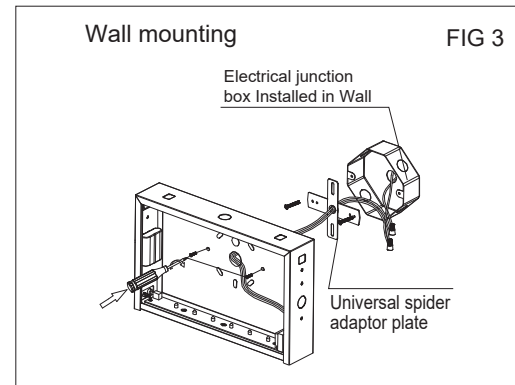
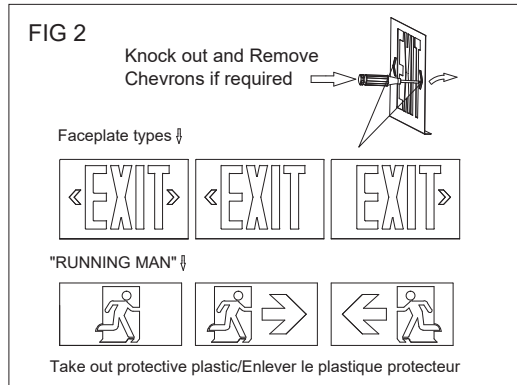
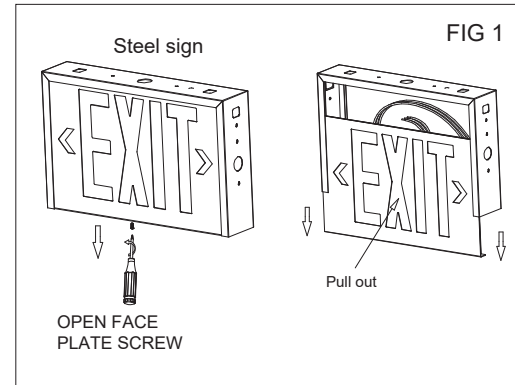

INSTALLATION

Wall Mount(Single Face Only):

1. Extend un switched 24 hour AC supply of rated voltage to a junction box (supplied by others) installed in accordance with all applicable codes and standards, Leave a minimum of 8 inches of slack on the wire, This circuit should not be energized/live at this time.
2. Remove the faceplate, Remove and discard the canopy kit located inside the sign cavity(Fig.1).
3. For installation directly over on an electrical junction box, the sign is supplied with universal spider knockouts stamped into the backplate, Aitematively, conduit knockouts are stamped into the top and side for surface wire conduit connection(Fig.3),- Knock out the appropriate holes and bring wires through the hole and into the sign.
4. Mount the sign securely into place.

5. Make proper wiring connections between the incoming AC supply and the circuit board transformer:RED=Line 347 Volts:BLACK=Line 120 Volts:WHITE=Neutral,BROWN is provided instead of RED for special voltages, Insulate unused wire! Connect ground to supplied green ground wire in accordance with local codes, Reassemble all wire connections and connectors,CAUTION!-Failure to insulate unused wire may result in a shock hazard or unsafe condition as well as equipment failure.
6. OPTIONAL-SELF-POWERED:plug battery connector into matching battery pins on led circuit board,(fig,5).
7. Secure all internal wires.
8. Knockout and remove any repaired directional chevron/arrows from the sign faceplate(FIG,2).
9. Slide the faceplate and stencil fibre into the sign frame,then replace and secure the faceplate screw.
10. Turn on ac line voltage supply.

Ceiling or End Mount(Single or Double Face):

1. Follow Steps 1 to 2 of wall mounting except DO NOT discard the canopy kit located inside the sign.
2. If double face is required,remove the backplate and install the second faceplate.
3. A single wire pass_thru and a pair of canopy screw knockouts are stamped into the top and also the end of the sign,Knock out the appropriate set of three holes:top holes for ceiling mount or end holes for end wall mount(Fig.4).
4. Secure the canopy to the sign using the supplied hardware.
5. Feed all wiring into the sign through the wire pass_thru hole.
6. Mount the sign securely to the wall or ceiling,the hole spacing in the canopy is designed to fit most standard electrical junction boxes,A steel,universal spider plate is supplied to allow mounting to alternate size/type boxes(fig.4).
7. Follow Steps 5 to 11 of wall mounting to complete installation.

* END MOUNT OPTION IS NOT AVAILABLE FOR BILINGUAL SIGNS

OPERATION AC ONLY & AC/DC MODELS

1. Sign will illuminate when supplied with power. Internally Self_Powered models only
2. To TEST, press the TEST Switch,The AC indicator will go out and the LED will switch to battery power.
3. Release the TEST Switch,The LED will switch back to AC power and the AC indicator will come on.

WHEN USING ELECTRICAL EQUIPMENT, BASIC SAFETY PRECAUTIONS SHOULD ALWAYS BE FOLLOWED, INCLUDING THE FOLLOWING:

1. Read and follow all safety instructions.
2. For indoor use ONLY.
3. Do not let power cords touch hot surfaces.
4. Do not install near gas or electric heaters.
5. Use caution when servicing batteries, Battery acid can cause burns to skin and eyes,if acid is spilled on skin or eyes,flush acid with fresh water and contact a physician immediately.
6. Equipment should be mounted in locations and at heights where unauthorized personnel will not readily subject it to tampering.
7. The use of accessory equipment not recommended by manufacturer, may cause an unsafe condition, and will void the unit's warranty.
8. Do not use this equipment for other than its intended use.
9. Servicing of this equipment should be performed by qualified service personnel.
10. Save These Instructions For Future Reference.

MAINTENANCE

1. Code requires that the equipment be tested every 30 seconds,and that written records be maintained for all test results and repairs,Further,the equipment is to be tested once a year for the required duration as per Code,The battery is to be replaced or the equipment repaired whenever the equipment fails to operate as intended during the duration test,the manufacturer strongly recommends compliance with all code requirements.
2. Clean face(s) on a regular basis to provide maximum performance in case of an emergency,
NOTE:The servicing of any parts should be performed by qualified service personnel only,The use of replacement parts not furnished by the manufacturer,may cause equipment failure and will void the warranty.

TROUBLESHOOTING HINTS

SIGN DOES NOT LIGHT UP/TURN ON AT ALL

1. Check AC supply-be sure unit has 24 hour AC supply(unswitched).
2. Check AC connector,The transformer/capacitor input power assembly is connected to the LEDcircuit board with a plastic connector, insure that this connector is firmly plugged into the LED circuit board,The connector will only lock into place when inserted with the correct orientation.
3. Check AC connections to transformer/capacitor assembly.insure that input voltage wiring matches the markings on the transformer/capacitor assembly wires being used.
4. AC supply and connections are ok and LEDs fail to light:replace LED Board Assembly.

SIGN LEDs DO NOT LIGHT UP/TURN ON WHEN DC POWER APPLIED

1. Check DC wire connections.insure that DC input voltage wiring matches the markings on the LED BOARD SIRENS BEING USED AND POLARITY IS CORRECT.
2. Insure DC wires are firmly soldered to LED circuit board.
3. DC supply and connections are ok and LEDs.

SIGN TURNS ON DIM WHEN AC POWER IS ON

1. Check supply voltage and AC connections,The AC supply must be at least 80% of nominal(96V on a 120V line)for equipment to function normally,At lower voltages,the LEDs may begin to glow dimly until the source voltage drops below the full batteries turn_on point.
2. Check AC connections to transformer/capacitor assembly.insure that a 120 Volt supply line has not been connected to the 347 Volt transformer/ capacitorlead wire.

SIGN COMES ON WHEN BATTERY IS FIRST CONNECTED(NO AC)

This is normal when the battery has enough charge to power the LEDs The sign will remain lit until the battery is discharged.

SIGN COMES ON DIM WHEN TEST BUTTON IS PRESSED

Internally Self_Powered Signs Only

1. Battery is severely discharged,Allow 24 hours for recharge and then retest,NOTE;This could be the result of a switched AC supply to the unit(which has been turned off at some point),a battery with a shorted cell, an old battery or a battery which has been discharged due to a long power outage and is not yet fully recharged.
2. If LEDs are still dim on test,replace battery.



WARNING:

Caution: Always turn off AC power to the equipment before servicing, Servicing should be performed only by a qualified service technician,Use only MANUFACTURER supplied replacement parts, Unused wires must be capped using enclosed wire nuts

