

Warning note

This product is an embedded emergency downlight with test switch and indicator light. It has functions such as charge protection, discharge protection, self-test and manual simulation test, and automatic conversion of emergency mode. The product design conforms to UL-924 requirements.

Model list:

Model No.	TLEST24
Input Voltage	DC 3.6V-24V
Input Current	DC 3.6V: 550-620mA DC 12V: 290-330mA DC 24V: 160-200mA
Input Power	DC 3.6V: 1.8-2.2W DC 12V: 3.6-4.4W DC 24V: 3.6-4.4W
Emergency Luminance Flux	DC 3.6V: ≥ 140LM DC 12V: ≥ 180LM DC 24V: ≥ 180LM
Operation Temperature	0°C-40°C
Correlated Color Temperature	5700K-6700K
Max. mounting height	13.8 ft (4.1 m)
Dimension	125x185x129mm
Weight	0.26kg
Warranty	2 years

Installation instruction diagram:

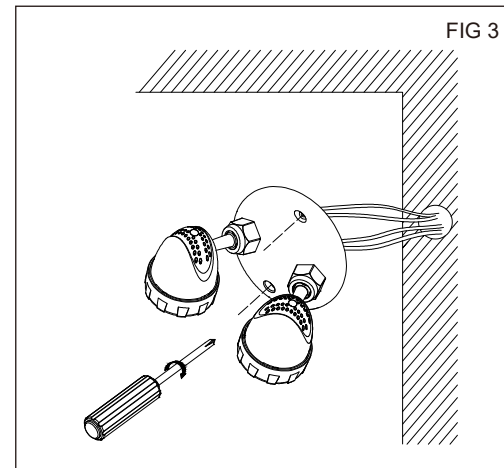
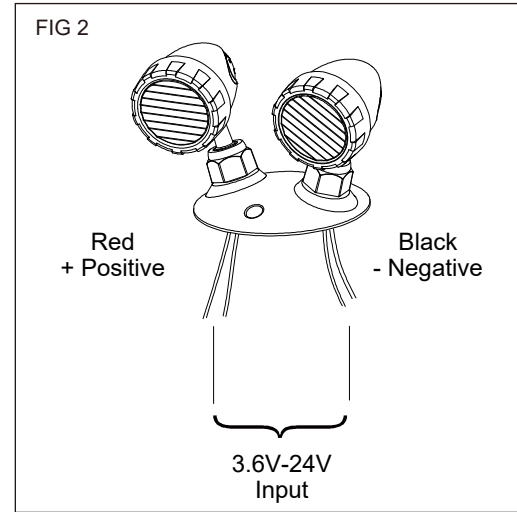
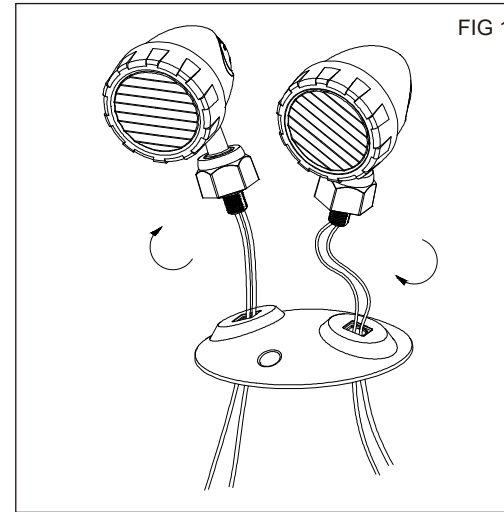

ELECTRICAL CONNECTIONS

1. Feed the wires through the hole on the bottom and twist the nut to fix it. (Fig 1)
2. Connect the wires to proper power supply and fix it on the wall with screws. (Fig 2, 3)
3. The max. mounting height is 13.8 ft (4.1 m).

Package Contents

Part	Description	Quantity
1	LED remote head	1

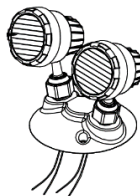

IMPORTANT SAFEGUARDS

READ AND FOLLOW ALL SAFETY INSTRUCTIONS

1. Review the diagrams thoroughly before beginning.
2. All electrical connections must be in accordance with local codes, ordinances and the National Electric code.
3. Disconnect power at fuse or circuit breaker before installing or servicing.
4. Do not use outdoors.
5. Do not mount in hazardous locations, or near gas or electric heaters.
6. Do not let power cords touch hot surface.
7. Equipment should be mounted in locations and at heights where it will not be subjected to tampering by unauthorized personnel.
8. The use of accessory equipment not recommend by the manufacturer may cause an unsafe condition.
9. Do not use this equipment for other than intended use.
10. All servicing should be performed by qualified personnel only.

 This marking indicates that this product should not be disposed with other household wastes throughout the EU. To prevent possible harm to the environment or human health from uncontrolled waste disposal, recycle it responsibly to promote the sustainable reuse of material resources. To return your used device, please use the return and collection systems or contact the retailer where the product was purchased. They can take this product for environmental safe recycling.

LUMINOUS INTENSITY DISTRIBUTION DIAGRAM

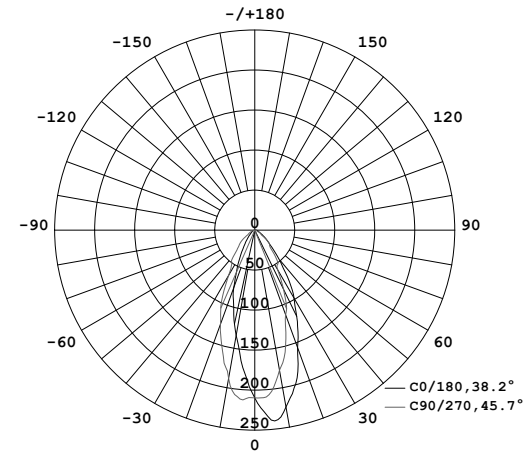

DC12V

C0 PLANE ISOLUX DIAGRAM (UNIT:lx)

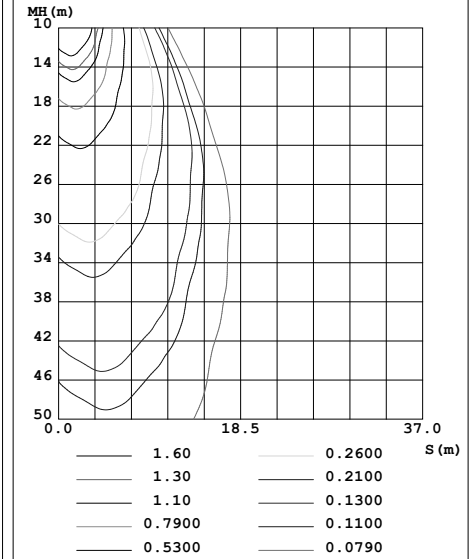

LUMINOUS INTENSITY DISTRIBUTION DIAGRAM

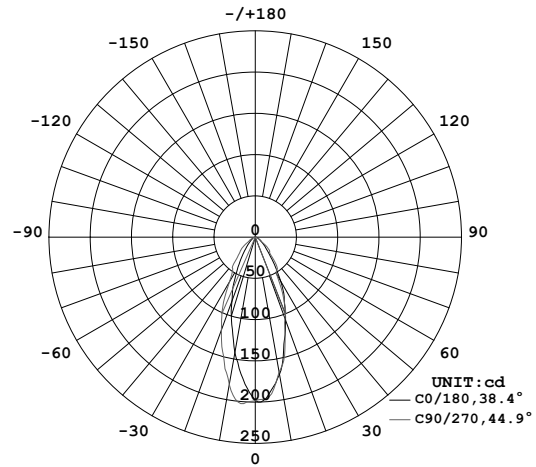

DC3.6V

C0 PLANE ISOLUX DIAGRAM (UNIT:lx)

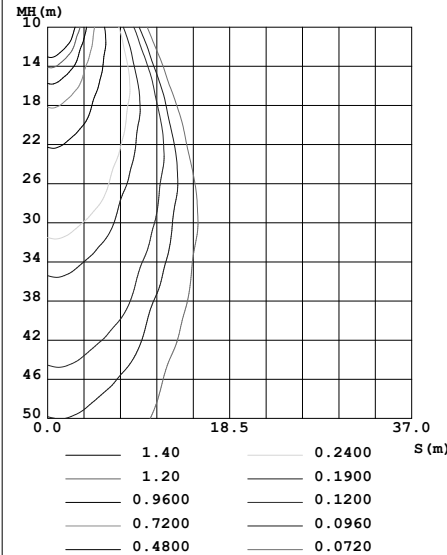

LUMINOUS INTENSITY DISTRIBUTION DIAGRAM

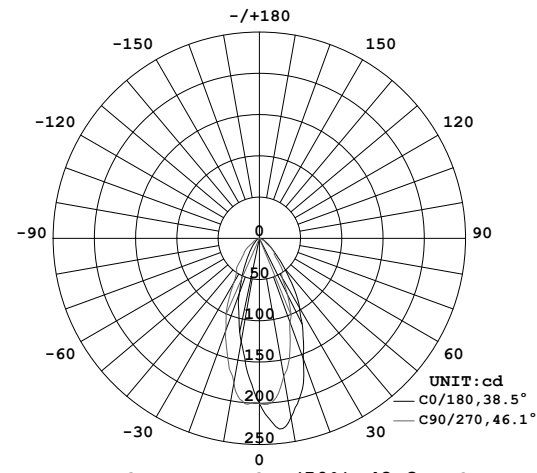

DC24V

C0 PLANE ISOLUX DIAGRAM (UNIT:lx)

