

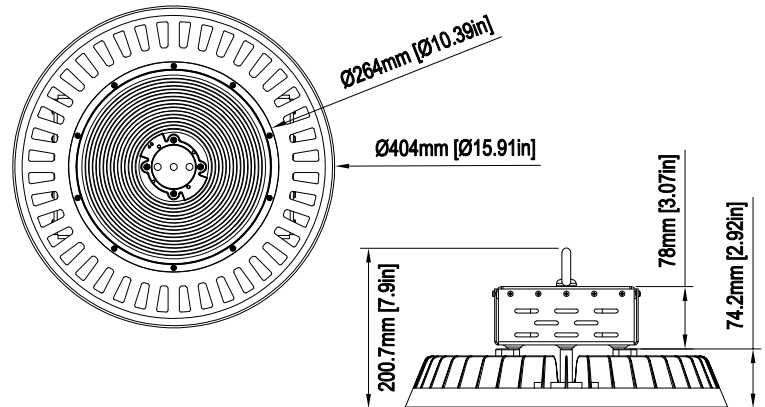

Selectable power



## Specifications TLHBUS300120N

### Electrical specifications

Model No.	TLHBUS300120N
DLC ID	S-5FGA3W
Power (W) ± 10%	200 W / 240 W / 300 W
Input Voltage (V)	120-347 V, 50/60 Hz
Efficacy ± 3%	169 lm/W
Power Factor (PF)	0.9
Dimmable	0-10 V
Surge protection	4 Kv
Total harmonic distortion	<20%





### Photometric specifications

CRI	83	
CCT	4 000 K	
Beam angle	120°	
Light Output ± 3%	200W: 33 800 lm	240W: 40 560 lm
	300W: 50 000 lm	

### Mechanical specifications

IP Rating	IP65
Material	Aluminum
Lens	Clear (Polycarbonate)
Net Weight	5.1 kg
Product size (mm)	± Ø404 x 200.7 mm
Product size (inch)	± Ø15.91 x 7.9 in
Operating Humidity	10% - 90%
Operating Temperature	-40°C ~ 50°C
Lifespan (L70)	60 000 hours

### Accessories not included

 HD09VR-PHC-DG	PIR motion sensor	 TLHBU3AR	Aluminum reflector
 HD06R	Remote control setting for motion sensor	 BLD-RM60R	Emergency lighting battery 100/347 V (Optional remote)

### Product description:

- Selectable power: 200 W / 240 W / 300 W.
- 5 000 K available.
- Lightweight lamp body for easier installation in high ceiling areas.
- Polycarbonate lens with 120° projection. 90° lens available on request.
- 600 mm stainless steel suspension kit included.
- 2 meters power cable.
- Over 70% energy saving compared to conventional lights.

### Applications:

Warehouse, workshop, garage, industry, arena and other high ceiling areas.