

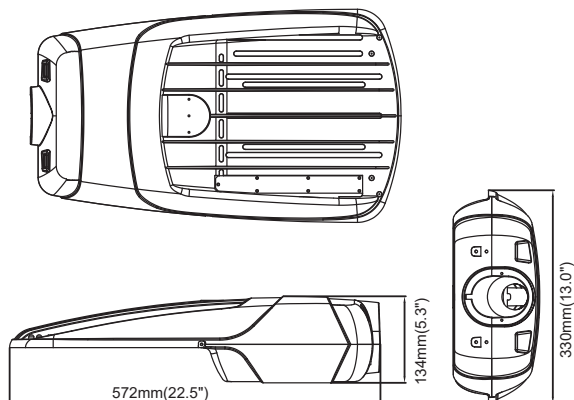

# TLSLUS140T3AGRR7

## Street light



### Specifications TLSLUS140T3AGRR7

#### Electrical Specifications

Model No.	TLSL150T3NGRR7
DLC ID	N/A
Power (W) ± 10%	80W / 120W / 140W
Input Voltage (V)	120-347V, 50/60Hz
Efficacy ± 3%	120 lm/W
Power Factor (PF)	>0.9
Dimmable	0-10V
Replace MH/HPS	300 W
Surge protection	10 kv
Total harmonic distortion	<15%

#### Photometric Specifications

CRI	>70
CCT	2200K / 3000K / 4000K
Beam angle	Type III
Light Output ± 3%	9 600 lm / 14 400 lm / 16 800 lm
BUG rating	B2-U0-G2

#### Mechanical Specifications

IP Rating	Damp locations
Material	Aluminum
Lens	PC
Net Weight	2.8 kg
Product size (mm)	± 572 x 330 x 134 mm
Product size (inch)	± 22.5" x 13" x 5.3"
EPA	0.8 ft <sup>2</sup>
Operating Humidity	10% - 90%
Operating Temperature	-40°C ~ 50°C
Lumen maintenance	>83% at 100 000 hours

### Product description:

- Tool-free maintenance.
- 7 pin receptacle included.
- Selectable power and CCT.
- Photocell or short-circuit cap sold separately.
- Easily replace traditional MH or HPS luminaire fixture.
- Powerful light efficacy and uniform illumination.
- Saves in electricity consumption compared to MH and HPS lighting fixture.
- Color: gray.
- Other colors available on special request.
- Warranty: 5 Years.

### Applications:

Street light. Suitable for parking lots, driveways, large spaces, etc.

#### Optional accessories



[info@technilight.ca](mailto:info@technilight.ca)

[WWW.TECHNILIGHT.CA](http://WWW.TECHNILIGHT.CA)