

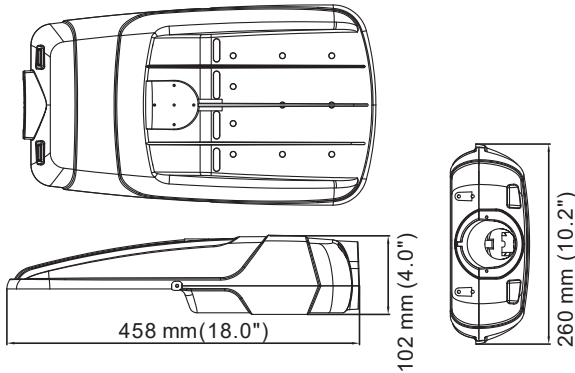

TLSLUS70T3AGRR7

Street light



Specifications TLSLUS70T3AGRR7

Electrical Specifications

Model No.	TLSLUS70T3AGRR7
DLC ID	N/A
Power (W) $\pm 10\%$	25W / 40W / 70W
Input Voltage (V)	120-347V, 50/60Hz
Efficacy $\pm 3\%$	120 lm/W
Power Factor (PF)	>0.9
Dimmable	0-10V
Replace MH/HPS	150 W
Surge protection	10 kv
Total harmonic distortion	<15%

Photometric Specifications

CRI	>70
CCT	2200K / 3000K / 4000K
Beam angle	Type III
Light Output $\pm 3\%$	3 000 lm / 4 800 lm / 8 400 lm
BUG rating	B1-U0-G1

Mechanical Specifications

IP Rating	Damp locations
Material	Aluminum
Lens	PC
Net Weight	2.8 kg
Product size (mm)	$\pm 458 \times 260 \times 102$ mm
Product size (inch)	$\pm 18" \times 10.2" \times 4"$
EPA	0.5 ft ²
Operating Humidity	10% - 90%
Operating Temperature	-40°C ~ 50°C
Lumen maintenance	>84% at 100 000 hours

Product description:

- Tool-free maintenance.
- 7 pin receptacle included.
- Selectable power and CCT.
- Photocell or short-circuit cap sold separately.
- Easily replace traditional MH or HPS luminaire fixture.
- Powerful light efficacy and uniform illumination.
- Saves in electricity consumption compared to MH and HPS lighting fixture.
- Color: gray.
- Other colors available on special request.
- Warranty: 5 Years.

Applications:

Street light. Suitable for parking lots, driveways, large spaces, etc.

Optional accessories



info@technilight.ca

WWW.TECHNILIGHT.CA