

Explosion proof

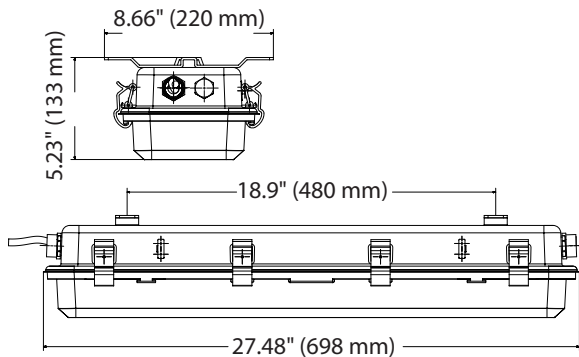

Specifications TLVPER2F30HP

Electrical specifications

Model No.	TLVPER2F30HP
Power (W) ± 10%	30 W
Input Voltage (V)	AC200-480V, 50/60Hz
Efficacy ± 3%	140 lm/W
Power Factor (PF)	0.9
Surge protection	4 Kv

Photometric specifications

CRI	>80
CCT	5 000 K
Beam angle	120°
Light Output ± 3%	4 200 lm
Dimmable	0-10 V

Mechanical specifications

IP Rating	IP66
Material	Aluminum + PC
Lens	Frosted
Net Weight	5.27 kg
Product size (mm)	± 698 x 220 x 133 mm
Product size (inch)	± 27.48 x 8.66 x 5.23"
Operating Humidity	N/D
Operating Temperature	-40°C ~ 50°C
Lifespan	N/D

Product description:

- UL844: Dangerous places
CAN / CSA-C22.2 NO. 137
CLASS 1 - DIVISION 2 - GROUP A, B, C, D
CLASS 2 - DIVISION 1 - GROUP E, F, G
CLASS 2 - DIVISION 2 - GROUP F, G
CLASS 3
- Savings on energy consumption compared to HPS / MH lighting.
- Warranty: 5 years.
- Other CCT available on request.
- Color: Gray.

Applications:

Areas with risk of explosion (gas emissions), areas with vapor or dust, petrochemical complexes, mines, etc.

Designed for wet locations.

Indoor and outdoor.

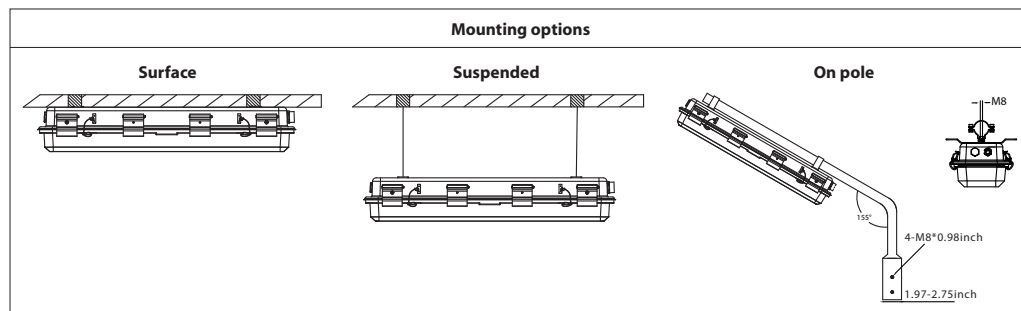

info@technilight.ca

WWW.TECHNILIGHT.CA